

ILLUSTRATED PARTS LIST

MFG. ID NO. 96051019000

CUSTOMER CATALOG NO. TC 238T

PRODUCT NO. 960 51 01-90

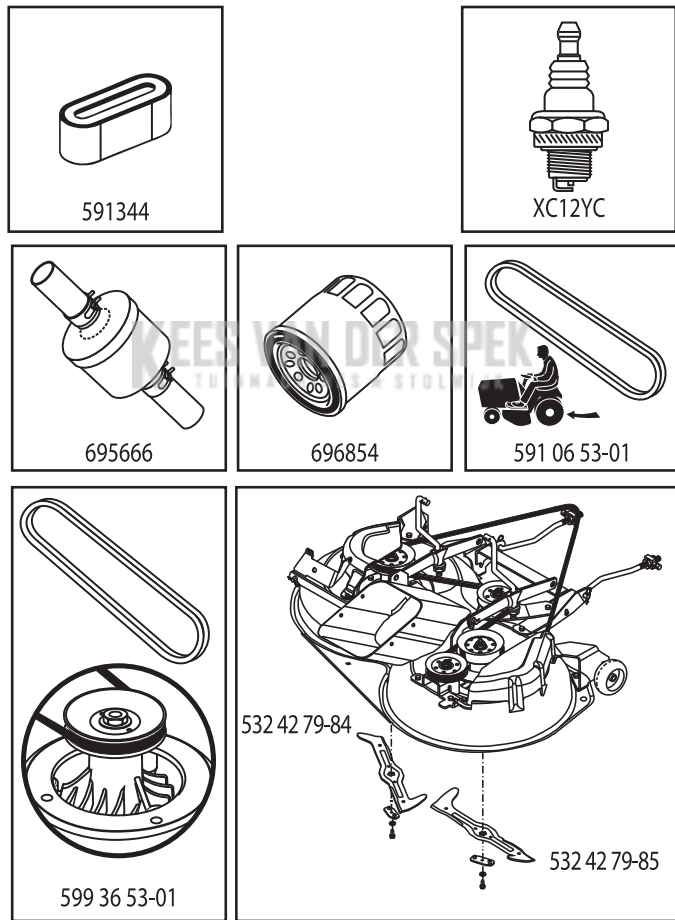

596396101

TRACTOR - MODEL NO. TC 238T (96051019000), PRODUCT NO. 960 51 01-90
DECALS 27

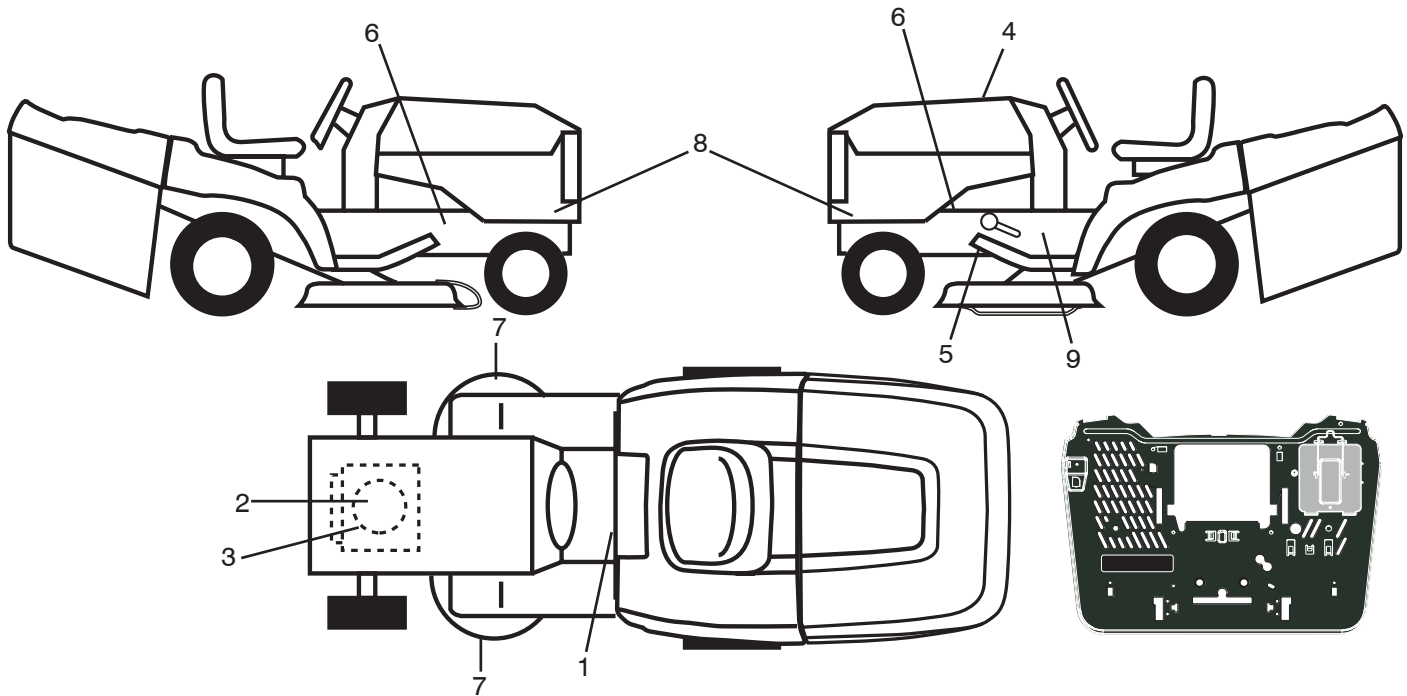

KEY NO.	PART NO.	DESCRIPTION
1	586 35 06-01	Decal, Warn Combined
2	581 57 97-01	Decal, Warning Eng. Sym.
3	587 38 53-01	Decal, Engine
4	596 39 61-01	Decal, Replacement
5	592 98 02-01	Decal, Belt Schematic
6	581 57 96-01	Decal, Chassis Hot Muffler
7	581 57 91-01	Decal, Mower Cut Finger Symbol
8	598 49 19-01	Decal, Side Panel
9	581 57 98-01	Decal, Warning

KEY NO.	PART NO.	DESCRIPTION
--	532 44 54-93	Decal, Warning
--	532 44 46-19	Decal, Bypass
--	532 44 14-09	Pad Footrest LH
--	532 44 14-10	Pad Footrest RH
--	114 20 44-20	Manual Operator's (Euro)
--	114 20 45-10	Manual Operator's (Scan)
--	114 20 46-50	Manual Operator's (E-Bloc)
--	114 20 47-40	Manual Operator's (Baltic)
--	114 20 48-76	Manual Operator's (Turkish)
--	114 20 49-53	Manual Operator's (Ukrainian)

WHEELS AND TIRES

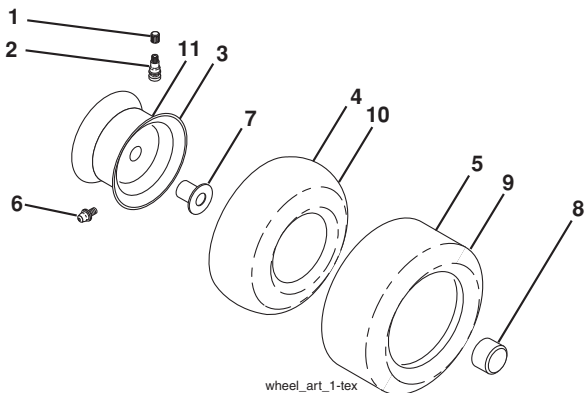

KEY NO.	PART NO.	DESCRIPTION
1	532 05 91-92	Cap Valve Tire
2	532 06 51-39	Stem Valve
3	532 13 83-36	Rim Front
4	532 05 99-04	Tube Front (Service Item Only)
5	532 10 62-22	Tire Front 15 x 6-6
6	532 00 02-78	Fitting Grease (Front Wheel Only)
7	532 00 90-40	Bearing Flange (Front Wheel Only)
8	532 17 50-39	Cap Axle Blk 1 50 x 1 00
9	532 12 46-35	Tire Rear 18 x 8.5 - 8 C
10	532 00 71-52	Tube Rear (Service Item Only)
11	532 13 83-37	Rim Asm 8" Rear
--	532 14 43-34	Sealant, Tire (10 oz. Tube)

NOTE: All component dimensions given in U.S. inches
 1 inch = 25.4 mm

TRACTOR - MODEL NO. TC 238T (96051019000), PRODUCT NO. 960 51 01-90

SCHEMATIC **38**

SCH17

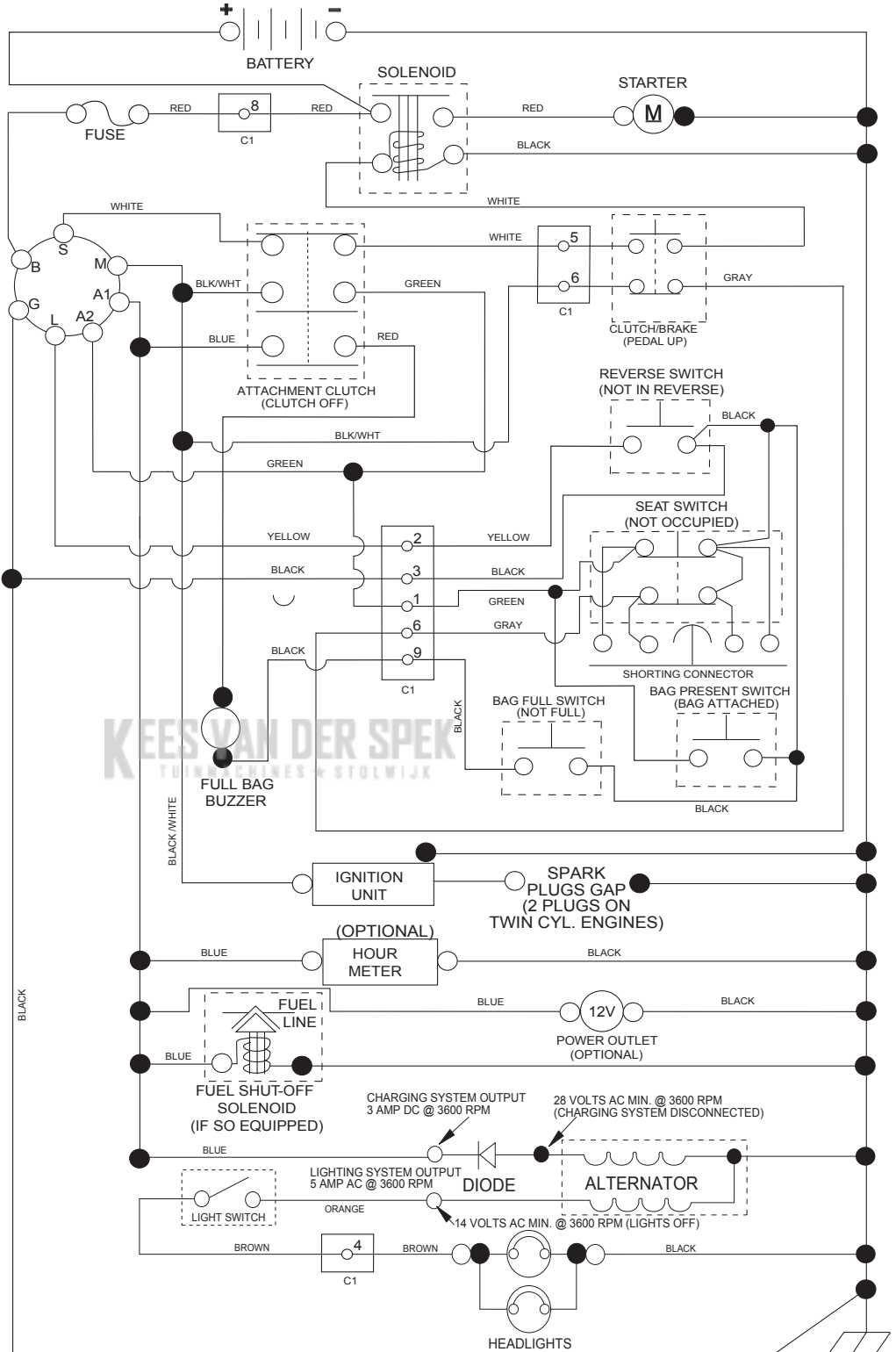

NOTE
 YOUR TRACTOR IS EQUIPPED WITH A SPECIAL ALTERNATOR SYSTEM. THE LIGHTS ARE NOT CONNECTED TO THE BATTERY, BUT HAVE THEIR OWN ELECTRICAL SOURCE. BECAUSE OF THIS, THE BRIGHTNESS OF THE LIGHTS WILL CHANGE WITH ENGINE SPEED. AT IDLE THE LIGHTS WILL DIM. AS THE ENGINE SPEED IS INCREASED, THE LIGHTS WILL BECOME THEIR BRIGHTEST.

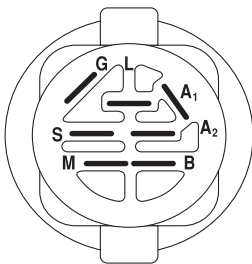

IGNITION SWITCH

POSITION	CIRCUIT	"MAKE"
OFF	M+G+A1	
RUN/OVERRIDE	B+A1	
RUN	B+A1	L+A2
START	B + S + A1	

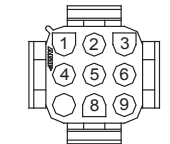

CHASSIS HARNESS CONNECTOR (C1) (MATING SIDE)

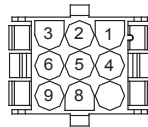

DASH HARNESS CONNECTOR (C1) (MATING SIDE)

WIRING INSULATED CLIPS
 NOTE: IF WIRING INSULATED CLIPS WERE REMOVED FOR SERVICING OF UNIT, THEY SHOULD BE RE-INSTALLED TO PROPERLY SECURE YOUR WIRING.

● NON-REMOVABLE CONNECTIONS
 ○ REMOVABLE CONNECTIONS

TRACTOR - MODEL NO. TC 238T (96051019000), PRODUCT NO. 960 51 01-90
ELECTRICAL **32**

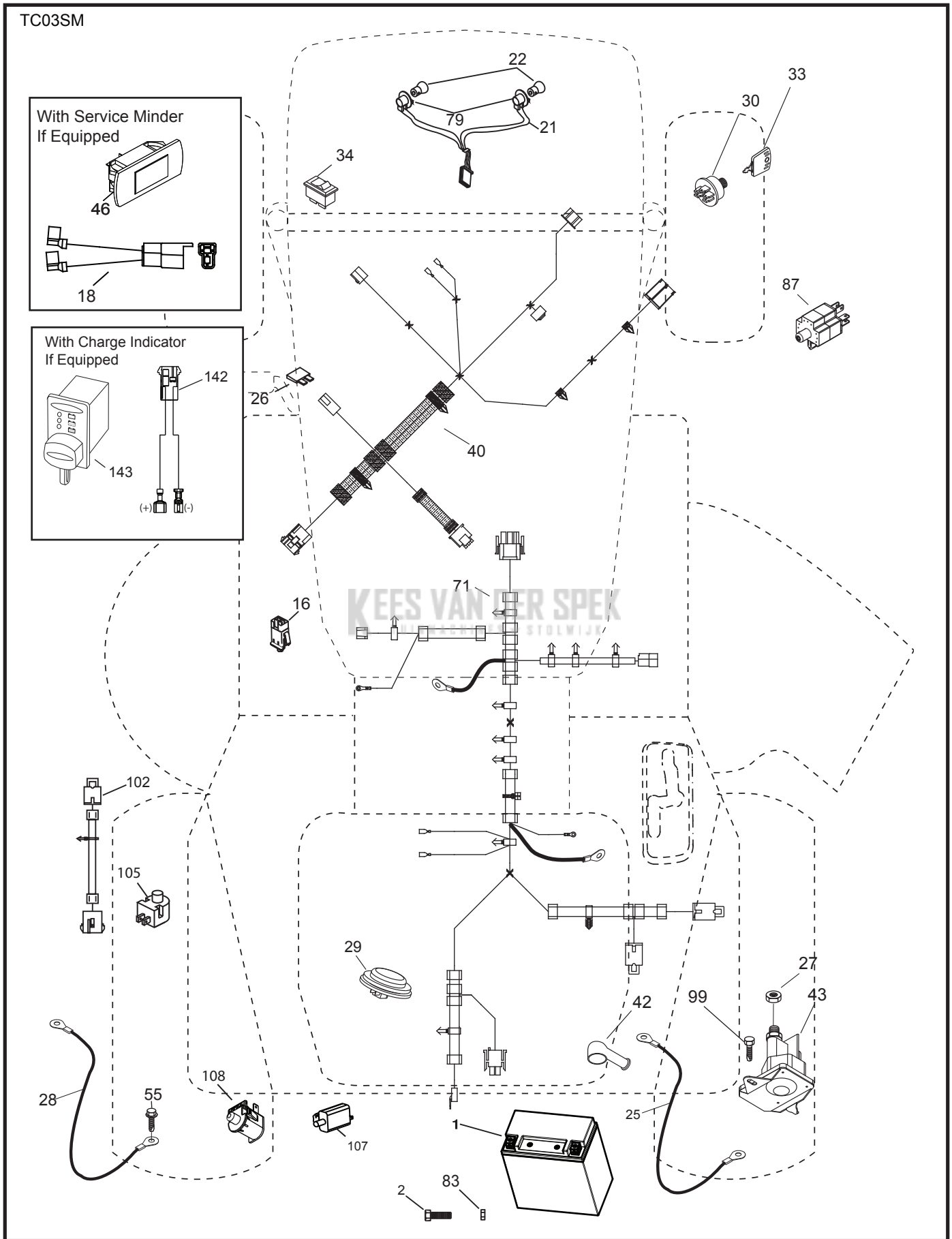

TRACTOR - MODEL NO. TC 238T (96051019000), PRODUCT NO. 960 51 01-90
ELECTRICAL 32

KEY NO.	PART NO.	DESCRIPTION
1	532 43 71-57	Battery
2	596 32 01-01	Bolt, Hex M6 x 12.4mm 8.8
16	532 17 61-38	Switch Interlock Push-In
21	532 40 02-52	Harness Light w/4152J
22	532 00 41-52	Bulb Light
25	589 32 37-01	Batt 8 Ga. Red 9 TCRD GN2
26	532 17 51-58	Fuse
27	596 13 36-01	Locknut, Keps 1/4-20
28	589 32 36-01	Cable Batt BICK10 SIV TCRD GN2
29	532 40 15-45	Switch, Seat
30	532 19 33-50	Switch, Ign
33	532 41 19-35	Key/Chain
34	532 11 07-12	Switch Light/Reset
40	585 84 99-01	Harness Ign. Dash
42	532 13 15-63	Cover, Terminal, Red
43	582 04 28-02	Solenoid
46	594 91 91-01	Hourmeter, Svc minder Rect.
55	817 06 05-12	Screw Thdrol 5/16-18 x 3/4 TYTT
71	587 26 87-01	Harness Ignition Chassis
79	532 17 52-42	Socket Asm. Bulb
83	594 08 65-01	Nut, Square, M6 x 1
87	532 42 10-60	Switch
99	817 00 05-12	Screw Hex Whs. Thdrol. 5-16-18 3/4
102	532 44 12-62	Harness Jumper
105	532 40 75-68	Switch Reverse
107	532 18 03-79	Switch Full Bagger
108	589 50 03-01	Switch Snapmount

NOTE: All component dimensions given in U.S. inches
 1 inch = 25.4 mm

TRACTOR - MODEL NO. TC 238T (96051019000), PRODUCT NO. 960 51 01-90
CHASSIS AND ENCLOSURES **39**

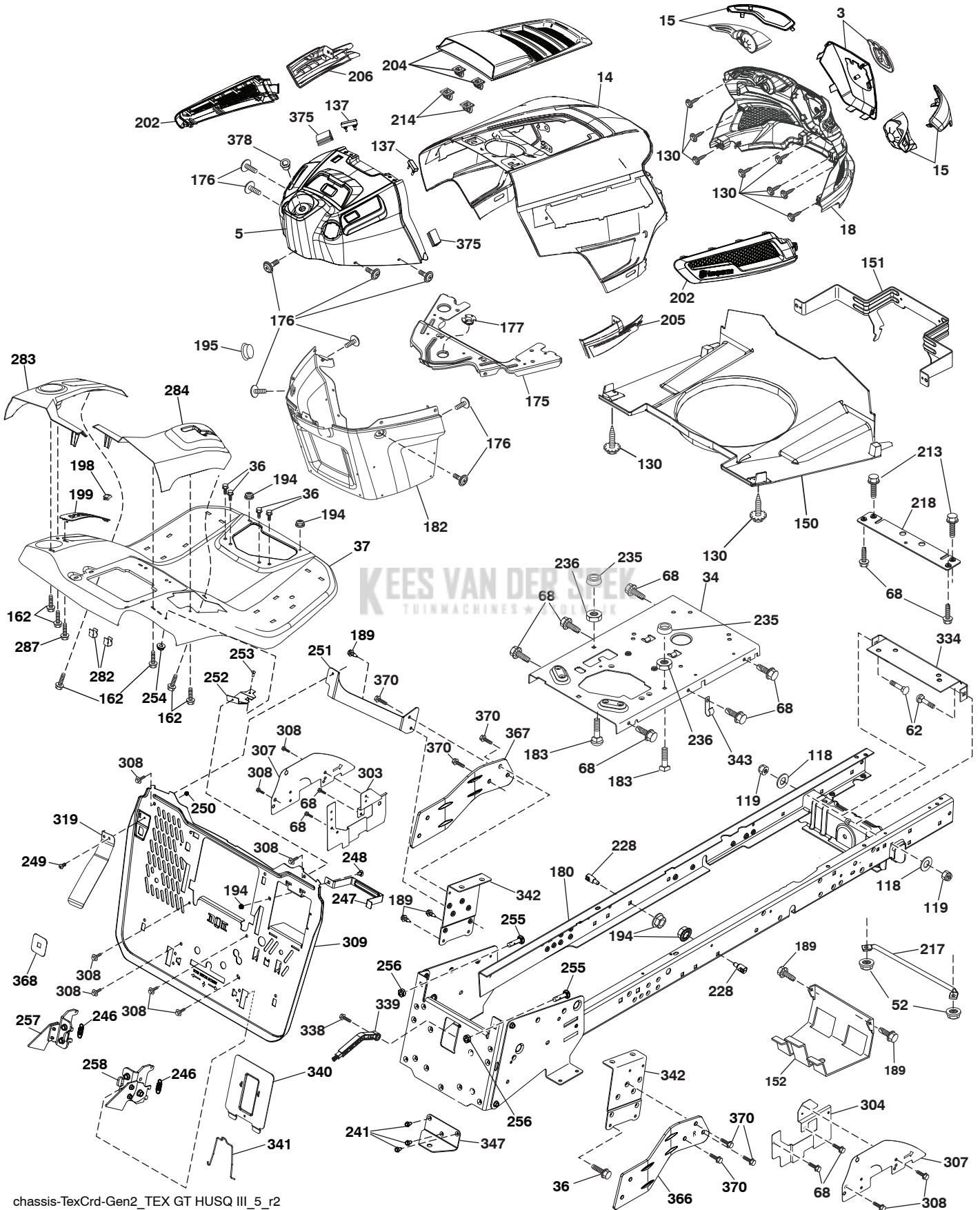

chassis-TeXCrd-Gen2_TEX GT HUSQ III_5_r2

TRACTOR - MODEL NO. TC 238T (96051019000), PRODUCT NO. 960 51 01-90
CHASSIS AND ENCLOSURES 39

KEY NO.	PART NO.	DESCRIPTION	KEY NO.	PART NO.	DESCRIPTION
3	597 68 82-01	Kit, Grille Applique, (includes applique cover and emblem badge)	236	873 93 05-00	Nut Lock 5/16-18 unc
5	590 74 88-23	Dash	241	593 33 76-01	Screw, 5/16-18 x 1.00 Hwh, Trs
14	532 44 11-77	Hood	246	591 44 90-01	Bagger Latch Extension Spring
15	597 86 78-01	Incandescent headlight kit (includes LH/RH lens and LH/RH housing)	247	582 55 26-02	Battery Strap
18	597 40 71-01	Grille	248	872 11 05-04	Bolt Rdhd Sqnk/16-18 x 1/2 Gr. 5
34	593 94 44-02	Plate Engine	249	586 93 60-01	Screw Bnhd 10-24 x 1/2 Patched
36	817 06 05-12	Screw 5/16-18 x 3/4	250	596 04 08-01	Lock, Nut, Washer, #10-24 in, Gr. 2
37	532 44 13-69	Fender	251	589 31 89-04	LH Backplate Support Bracket
52	596 04 05-01	Nut, Lock, Hex, Prvl, 5/16-18	252	581 99 22-04	RH Backplate Support Bracket
62	596 72 82-01	Bolt, Carrl, 3/8-16 x 1" Gr. 5	253	596 23 84-01	1/4-20 x 3/4 in, Gr. 5, Bolt,
68	596 03 07-01	Screw, Hexagon, 5/16-18 x 1/2	254	873 90 04-00	Nut Lock Hex Flange 1/4-20
118	596 56 53-01	Washer, 3/8x 0.08 In, St, Clr, Zinc	255	589 39 22-03	Bolt Cross Drilled 3/8-16 x 1.75
119	596 32 26-01	Nut, Crownlock, 3/8 x16, Unc	256	596 21 90-01	Nut Jam 3/8-16
130	596 32 17-01	Screw #10 x 0.750	257	589 74 66-02	Bagger Latch Assembly LH
137	532 40 75-90	Bumper Dash	258	589 74 67-02	Bagger Latch Assembly RH
150	532 43 97-74	Air Duct	282	532 41 41-10	Clip Retainer
151	532 43 66-70	Bracket Pivot	283	532 44 72-12	Console Deck Lift LH
152	532 19 95-35	Shield, Browning	284	532 44 72-20	Console Shft RH
162	596 13 41-01	Screw, Hex, Tap, 1/4-15 x 1/2	287	817 60 04-06	Screw 1/4-20 x 3/8
175	590 60 77-02	Crossmember	303	589 00 76-02	Shield Chassis French LH
176	532 40 07-76	Screw 10-24 x 5/8	304	589 00 68-02	Shield Chassis French RH
177	532 19 52-28	Bushing Steering	307	587 49 45-01	Shield Upper French
180	593 89 88-01	Chassis	308	532 17 18-77	Bolt 5/16-18 unc x 3/4 w/Sems
182	586 73 86-02	Dash Lower	309	582 55 25-02	Backplate
183	595 30 57-01	Screw, Hexagon, 5/16-18 x 1-1/4	319	581 31 39-07	Lever Bag
189	817 00 05-12	Screw 5/16-18 x 3/4	334	532 44 25-37	Bracket Engine
194	596 13 57-01	Nut, Lock, Prvl, Torq, 5/16-18 x .68	338	594 09 39-01	Bolt, Shoulder 5/16-18 x .88
195	532 40 41-37	Plug Hole Dash	339	532 43 66-41	Lever Bagger Full
198	532 44 15-52	Indicator Deck Lift	340	582 55 27-02	Battery Door
199	532 41 87-39	Plate Deck Lift	341	582 06 08-01	Battery Door Latch
202	597 86 77-01	Kit, Side Vents, LH/RH (includes LH/RH side vents)	342	582 82 68-02	Supprt Fender
204	597 40 80-01	Kit, Top Vent (includes top vent and clip retainers)	343	532 44 07-49	Clip
205	532 43 97-30	Skirt Side RH	347	532 44 28-87	Hitch Tow
206	532 43 97-29	Skirt Side LH	366	599 36 16-02	Bracket, RH. Front, Support, Bagger
213	596 03 05-01	Bolt, Hex, Hd, 5/16-18 unc x 3/4	367	599 36 19-02	Bracket, LH. Front, Support, Bagger
214	532 19 91-45	Clip Retainer	368	581 42 48-01	Full Lever Shroud
217	532 40 91-67	Rod Pivot	370	817 12 06-16	Screw, 3/8-16 x 1, Smgml, T
218	532 19 63-95	X-Piece Hood Stop	375	586 90 82-01	Dash Clip-On Bumper
228	593 82 40-01	Stud, w/"D" Anti-rotation	378	590 84 98-01	Bushing, Flange
235	596 56 42-01	Spacer, Fender, Clr, Zn			

NOTE: All component dimensions given in U.S. inches
1 inch = 25.4 mm

TRACTOR - MODEL NO. TC 238T (96051019000), PRODUCT NO. 960 51 01-90
DRIVE **40**

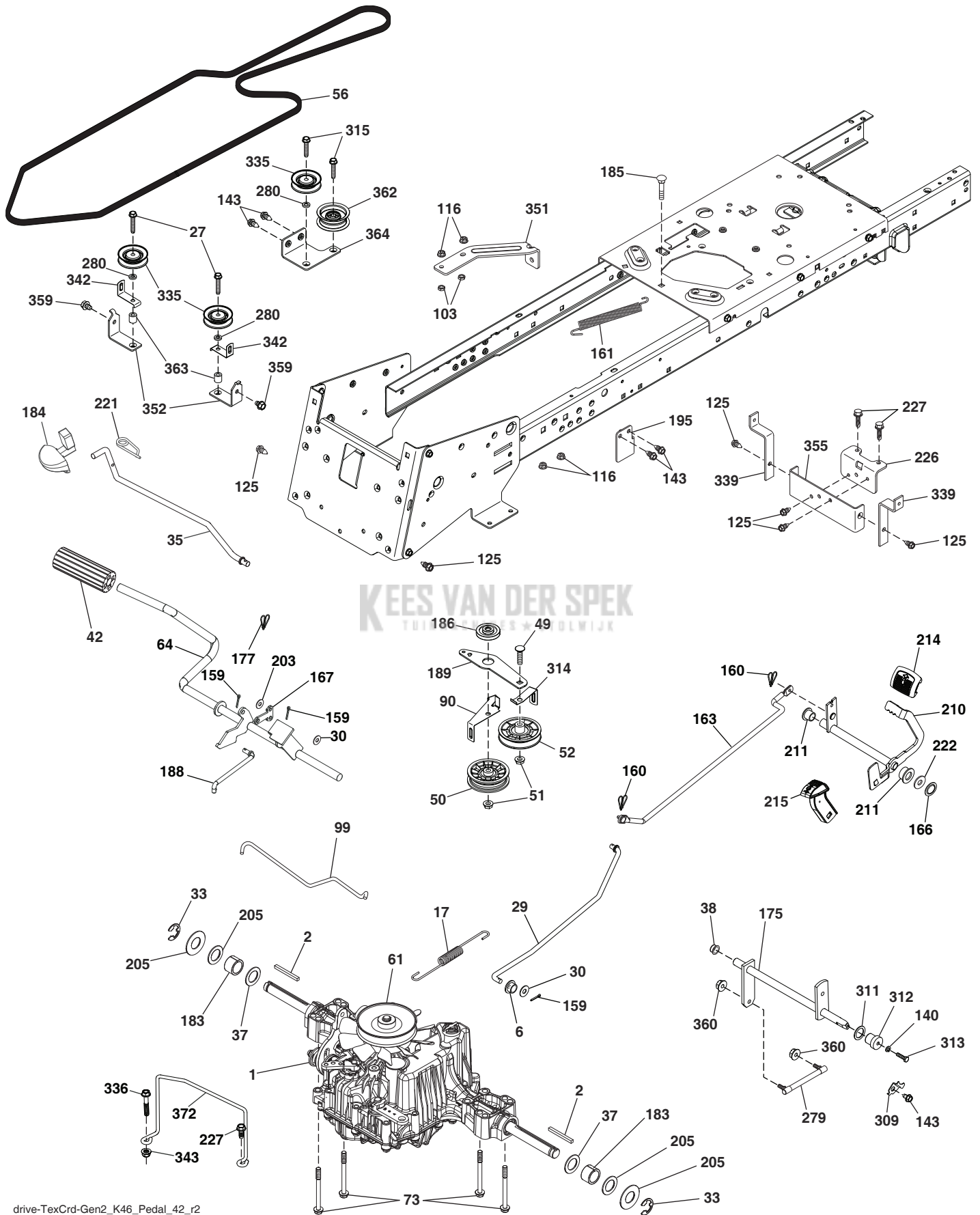

KEES VAN DER SPEK
TUIN EN HORTA
WOLWIJK

TRACTOR - MODEL NO. TC 238T (96051019000), PRODUCT NO. 960 51 01-90
DRIVE 40

KEY NO.	PART NO.	DESCRIPTION	KEY NO.	PART NO.	DESCRIPTION
1	---	Transaxle, Tufftorq K46DF (446488) (Order parts from trans-axle manufacturer.)	186	532 19 43-21	Spacer Retainer
2	532 12 35-83	Key Square	188	582 21 70-01	Link Clutch
6	532 12 40-28	Bushing Snap	189	532 43 36-11	Bellcrank Ground Drive
17	532 43 62-27	Spring Brake K46	195	580 45 69-01	Bracket Rod Brake CRD Tex
27	596 24 10-01	Screw, Hex. Threadroll. 5-16 x 18	203	596 20 41-01	Washer, 11/32 x 11/16 x 14
29	532 44 27-95	Rod, Brake	205	532 12 17-48	Washer 25/32 x 1-5/8 x 16 Ga.
30	596 14 02-01	Washer, .406 ID x OD x .065	210	532 40 09-80	Rocker Asm. Pedal Control
33	812 00 00-01	Ring E	211	532 12 01-83	Bearing Nylon
35	583 86 45-02	Rod, Brake, Park	214	532 42 12-63	Pedal Forward
37	532 18 89-67	Washer Harden .793 x 1.063 x .060	215	586 60 65-02	Pedal Reverse
38	532 16 96-13	Nyliner Bushing	221	532 40 31-87	Retainer Spring Clip Handle
42	532 00 88-83	Cover, Foot Pedal	222	879 21 20-10	Washer 21/32 x 1-1/4 10 Ga.
49	596 13 62-01	Bolt, Cup, Head .3/8-16 x 3/4	226	532 40 15-64	Bracket Strap Torque
50	532 19 43-27	Idler Flat	227	596 13 59-01	Bolt, Hex. 5/16-18 x 3/4.Clr.znc
51	873 90 06-00	Lock Nut 3/8-16	279	593 89 84-01	Link&Stud-Link, Subasm
52	532 19 43-26	Idler V-Groove	280	596 03 99-01	Washer, Plain 11/32 x 5/8.Clr.
56	591 06 53-01	V-Belt, Drive	309	532 16 55-81	Plate Fstnr Cross Shf
61	532 44 51-51	Pulley Transaxle K46	311	532 16 98-45	Washer Nylon
64	532 19 78-65	Shaft Asm. Pedal Brake Control	312	532 16 56-14	Hub Tapered
73	595 31 66-01	Bolt, Hhd w/Flange 5/16-18 Gr 5	313	596 04 07-01	Bolt, Hex. 1/4-20 x 1
90	532 44 36-05	Keeper Belt Clutching	314	532 44 47-13	Keeper Belt
99	532 44 39-47	Rod Spring Bypass	315	817 58 05-20	Screw Thdrol 5/16-18 x 4.25
103	596 43 63-01	Nut, Hex. 5/16-18 x 0.577" Gr. 5 Zn.	335	532 19 95-34	Pulley V-Idler
116	596 13 57-01	Nut, Lock. Prvl. Torq. 5/16-18 x .68	336	587 25 96-02	Bolt 5/16-18 x 1-3/4 Flanged hex
125	817 00 05-12	Screw 5/16-18 x 3/4	339	532 43 68-67	Strap Torque K46 CRD Tex
140	596 02 98-01	Spring, Lock. Washer, Square, Ends	342	532 18 26-82	Keeper Belt 2.5" STL V-Idlr CRD
143	596 03 07-01	Screw, Hexagon. 5/16-18 x 1/2	351	594 94 44-01	Nut, Hexagon, Flange 5/ 16 -18
159	596 02 95-01	Pin, Cotter, 1/8 Dia x 3/4	352	532 43 69-98	Bracket 97 CRD Deck Sway
160	596 02 94-01	Clip, Retainer"M"	352	532 43 56-45	Bracket Idler CRD Tex
161	532 10 57-09	Spring, Return, Clutch	355	532 43 56-69	Bracket
163	594 08 41-02	Rod, Cntrl. Shift, Pedal	359	596 56 40-02	Bolt, Hhd. 3/8-16 x 0.655 Clr. Zn.
166	532 42 91-64	Nut Push	360	532 44 47-14	Nut 5/16-24 unf
167	532 40 52-57	Latch Brake Parking	362	532 43 68-12	Idler Flat
175	532 42 93-59	Shaft Asm Crossshift Rear CRD	363	532 44 27-80	Spacer .343 x .63 x .62
177	587 22 53-01	Pin, Cotter, Locking, Bowtie, 1 In.	364	532 44 30-32	Bracket Idler CRD Tex
183	532 13 70-57	Spacer Axle	372	582 65 49-01	Keeper Belt Transaxle
184	587 65 37-01	Handle Parking Brake			
185	872 11 06-22	Bolt 3/8-16 unc x 2-3/4 Gr. 5			

NOTE: All component dimensions given in U.S. inches
1 inch = 25.4 mm

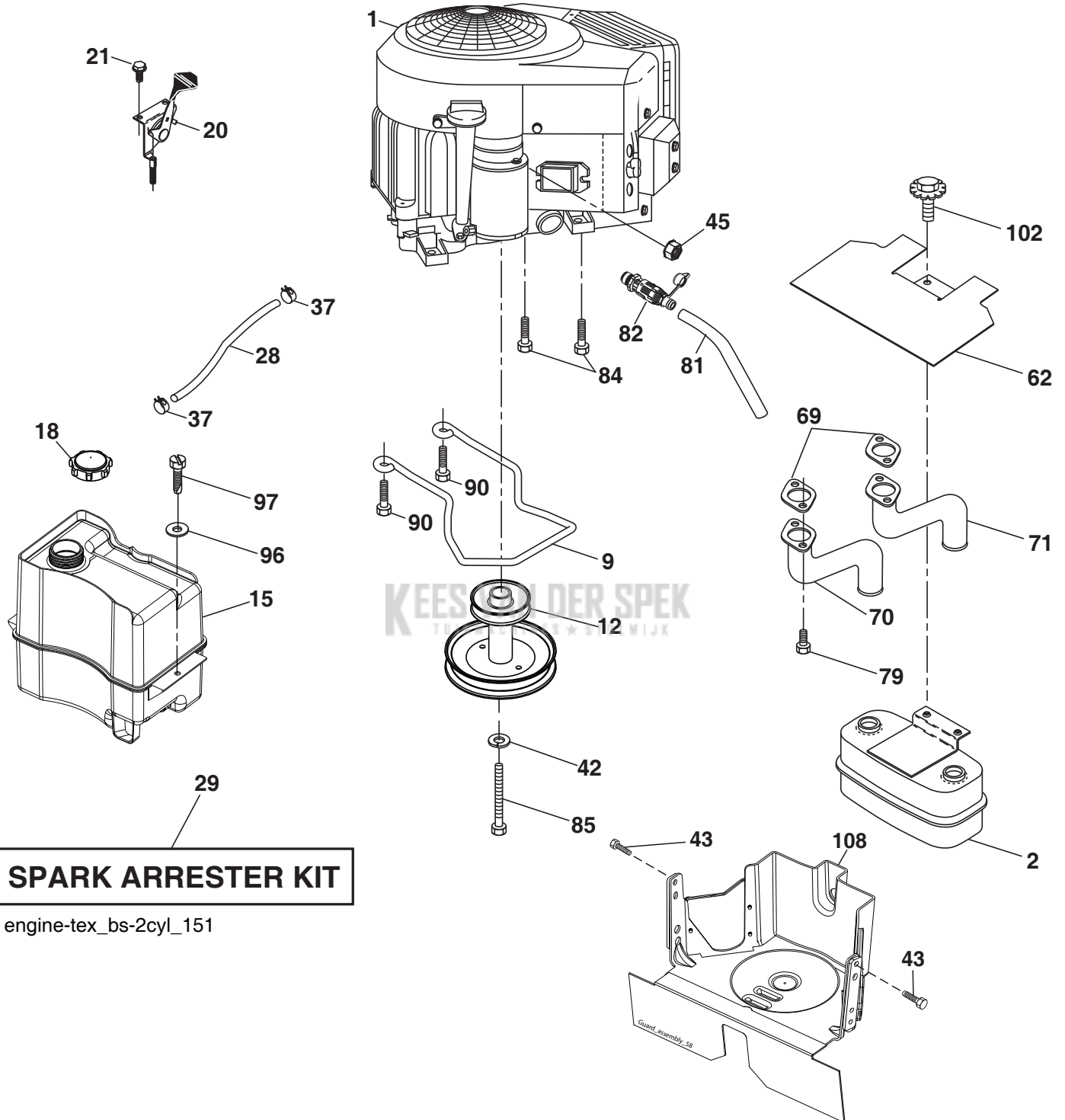

**TRACTOR - MODEL NO. TC 238T (96051019000), PRODUCT NO. 960 51 01-90
ENGINE 24**

KEY NO.	PART NO.	DESCRIPTION
1	-----	Engine B&S Model No. 40N777-0009-B5 (597818301) (Order parts from engine manufacturer.)
2	589 81 87-01	Muffler
9	501 83 26-02	Keeper Belt Engine
12	586 47 85-01	Pulley Engine
15	581 29 01-01	Tank Fuel
18	532 43 02-20	Fuel Cap
20	587 24 25-01	Control Throttle
21	596 32 17-01	Screw, #10 x 0.750, Bos. Thread
28	532 13 70-40	Fuel Line
29	532 13 71-80	Spark Arrester Kit
37	532 12 34-87	Clamp Hose
42	596 23 89-01	Washer 7/16" Clr. Zn.
43	593 33 76-01	Screw 5/16-18 x 1.00 Hwh. Trs
45	596 13 36-01	Locknut, Keps. 1/4-20
62	532 43 40-17	Shield Heat Muffler
69	532 16 53-91	Gasket
70	581 88 11-01	Tube Exhaust LH
71	581 88 10-01	Tube Exhaust RH
79	596 13 42-02	Screw, Socket, 5/16-18 x 1 Clr, Zn
81	532 14 84-56	Tube Drain Oil Easy
82	532 42 82-87	Valve Oil Drain
84	817 06 06-20	Screw
85	501 60 65-01	Bolt Hex 7/16-20 x 4 x Gr. 5-1.5 Thr
90	817 00 06-16	Screw 3/8-16 x 1
96	596 13 53-01	Washer Plain 9/32 x 7/8 Clr. Zn.
97	817 67 04-12	Screw 1/4-20 x 3/4
102	817 00 05-12	Screw 5/16-18 x 3/4
108	587 17 95-10	Cover Pulley Eng. w/SHLD

NOTE: All component dimensions given in U.S. inches
1 inch = 25.4 mm

TRACTOR - MODEL NO. TC 238T (96051019000), PRODUCT NO. 960 51 01-90
STEERING ASSEMBLY **41**

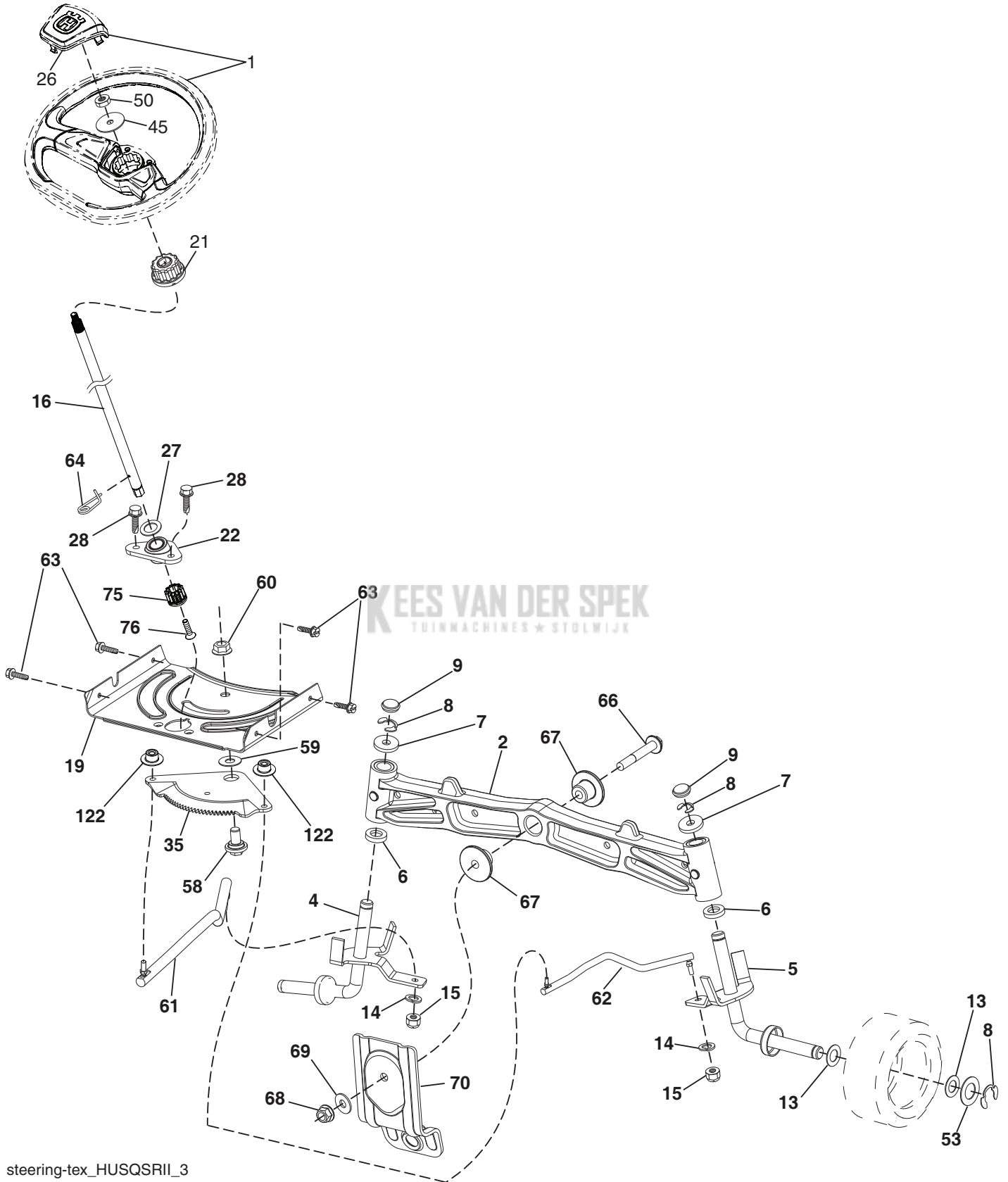

steering-tex_HUSQSR11_3

TRACTOR - MODEL NO. TC 238T (96051019000), PRODUCT NO. 960 51 01-90
STEERING ASSEMBLY 41

KEY NO.	PART NO.	DESCRIPTION
1	597 86 61-01	Wheel, Steering, Kit (includes steering wheel and cap)
2	532 19 59-68	Axle Asm.
4	532 40 30-87	Spindle, LH
5	532 40 30-88	Spindle, RH
6	532 00 62-66	Washer Thrust 0.75 x 1.23
7	532 12 17-48	Washer 25/32 x 1-5/8 x 16 Ga.
8	812 00 00-29	Ring, Klip #T5304-75
9	532 12 12-32	Cap, Spindle
13	532 12 17-49	Washer 25/32 x 1-1/4 x 16 Ga.
14	596 23 87-01	Washer, Spring, Lock .381 ID x .680
15	873 54 06-00	Nut, Crown Lock 3/8-24 unf
16	587 01 60-02	Steering Shaft
19	532 19 47-29	Plate Steering
21	586 84 02-01	Adapter Wheel Steering
22	585 02 98-02	Bearing
26	594 94 91-01	Cap, Wheel Steering
27	596 93 34-01	Washer, Plain
28	817 00 06-12	Screw 3/8-16 x 3/4
35	532 19 47-32	Gear, Sector Plate
45	587 01 64-01	Washer 3/8 ID 2-3/8 OD 12 Ga. PLTD
50	873 90 06-00	Nut Lock Flg 3/8-16 unc
53	532 18 89-67	Washer Hardened .793 x 1.637 x .060
58	532 19 47-47	Bolt Shoulder Sector Pivot CFM
59	532 19 47-48	Washer Thrust Sector Steering
60	873 97 10-00	Nut Flange Lock 5/8-11
61	597 04 78-02	Draglink, LH
62	597 04 79-02	Draglink, RH
63	817 00 05-12	Screw 5/16-18 x 3/4
64	532 19 98-49	Retainer Clip Spring Steering
66	871 02 07-48	Bolt Hex Fghd 7/16-14 x 3 Serr
67	532 19 47-37	Bushing PM Front Axle
68	873 90 07-00	Nut Lock Flange 7/16-14 Gr. 5
69	532 19 91-62	Washer 1.5 x .505 x .118
70	585 33 88-01	Bracket Deck Susp. Front
75	580 68 37-01	Pinion
76	580 68 36-01	Screw Head Sock
122	532 44 49-62	Cap Gear

NOTE: All component dimensions given in U.S. inches
1 inch = 25.4 mm

TRACTOR - MODEL NO. TC 238T (96051019000), PRODUCT NO. 960 51 01-90
MOWER DECK 44

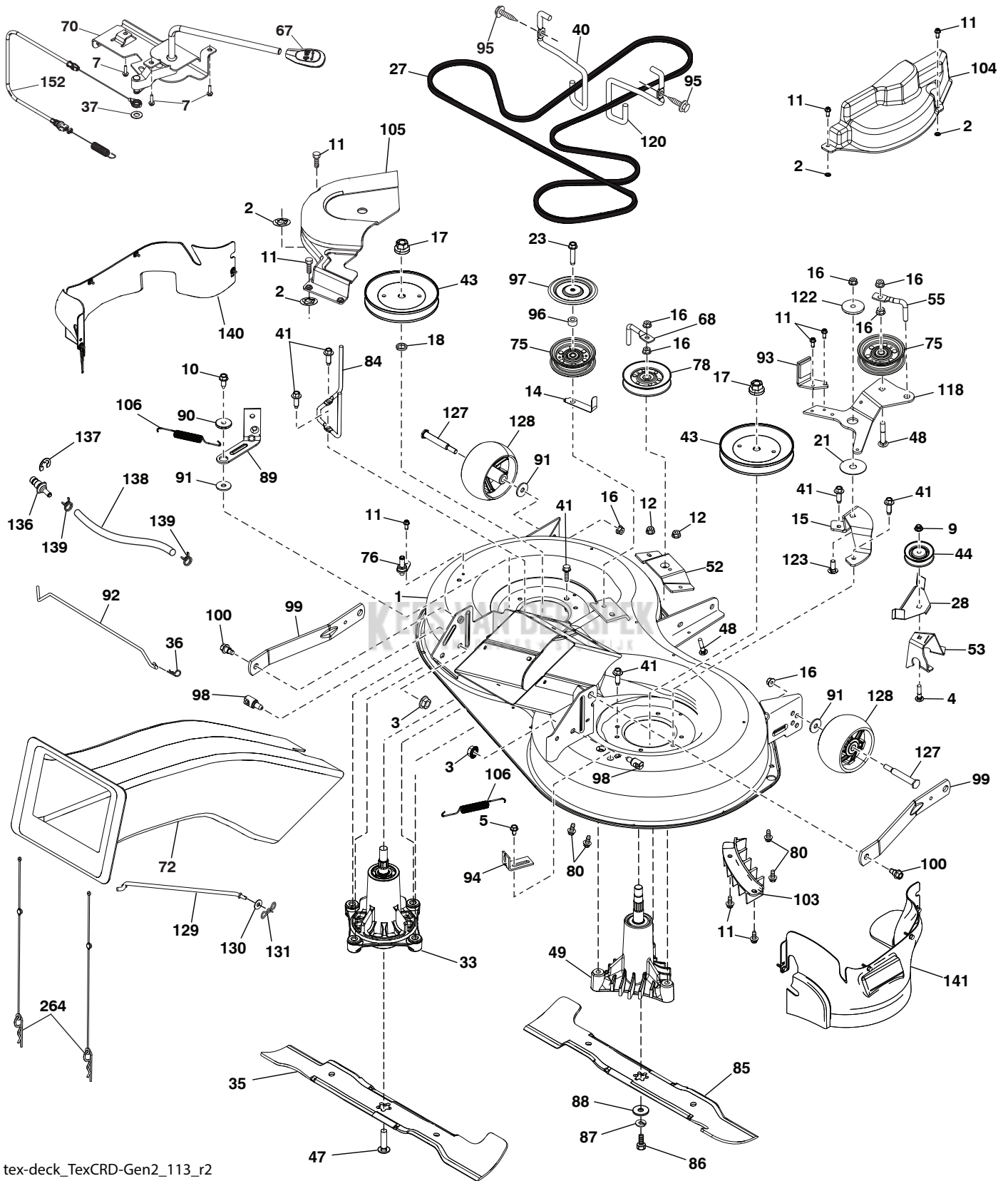

tex-deck_TexCRD-Gen2_113_r2

TRACTOR - MODEL NO. TC 238T (96051019000), PRODUCT NO. 960 51 01-90
MOWER DECK 44

KEY NO.	PART NO.	DESCRIPTION	KEY NO.	PART NO.	DESCRIPTION
1	592 97 00-01	SVC Weldment Kit	85	532 42 79-85	Blade
2	532 42 30-62	Palnut 1/4	86	532 18 17-13	Bolt 3/8-24 x 1.50
3	596 13 57-01	Nut, Lock, Prvl. Torq. 5/16-18 x .68	87	596 23 87-01	Washer, Spring, Lock .381 Id. x .680
4	872 11 05-10	Bolt Carr. 5/16-18 x 1-1/4 Gr. 5	88	532 14 02-96	Washer Hard Blade
5	817 00 05-10	Bolt 5/16-18	89	532 43 81-24	Arm Brake
7	596 32 17-01	Screw #10 x 0.750, Bos. Thread	90	532 19 90-92	Spacer Retainer
9	585 69 13-01	Nut Hex Flg Nylock	91	596 13 49-01	Washer, Plain 3/8 x 7/8
10	817 00 06-16	Screw 3/8-16 x 1	92	592 85 57-01	Rod Brake 97 CRD Link
11	532 13 77-29	Screw 1/4-20 x 5/8	93	592 85 49-02	Arm Brake
12	594 94 44-01	Nut, Hexagon, Flange 5/16-18	94	532 19 72-50	Bracket Clutch Cable
14	532 15 60-85	Keeper Belt Idler	95	817 00 06-12	Screw Hexwsh 3/8-16 x 3/4
15	592 85 47-02	CRD Idler Arm Mount Bracket	96	532 40 02-71	Spacer
16	873 90 06-00	Nut 3/8-16	97	532 18 20-61	Shield Idler Mower
17	596 13 48-01	Nut, Hex. 9/16-18 x 1.010	98	593 82 40-01	Stud, W/"D"Anti-Rotation
18	532 18 76-90	Washer Spacer Mandrel	99	532 19 51-86	Arm Suspension
21	532 17 85-15	Washer Flat Hardened	100	532 19 65-39	Bolt Shoulder
23	596 56 40-03	Bolt, Hex 3/8-16 x 1.78, Clr. Zinc	103	532 43 69-92	Guard Front Vent
27	599 36 53-01	Belt, Deck	104	592 84 81-01	Mandrel Cover RH
28	592 85 56-02	Keeper 97 CRD Angled Idler	105	532 43 87-44	Mandrel Cover LH
33	587 81 97-01	Kit, Mandrel, Non Grease,Tall (includes mandrel and bolts)	106	532 19 32-16	Spring Brake Return
35	532 42 79-84	Blade	118	599 23 63-02	97 CRD, Clutching, Arm, MS431
36	532 00 44-97	Retainer, Spring 1", Zinc/Cad	120	532 19 72-59	Keeper Belt Engine RH
37	596 56 53-01	Washer, 3/8 x 0.08", St. Clr. Zinc	122	532 16 57-23	Retainer Spring
40	532 19 72-58	Keeper Belt Engine LH	123	596 98 75-01	Bolt 3/8 x 1-1/4" Gr 5. Clr. Zn.
41	584 95 39-01	Bolt Hex Wshrhd .313-18 x 1.19	127	596 43 44-04	Bolt, Shoulder 3/8-16 x 3-5/8"
43	532 19 74-73	Pulley Mandrel	128	589 52 73-01	Wheel Gauge Rally
44	532 19 95-34	Pulley V-Idler GRND DR. Plated	129	532 44 32-37	Rod Anti-Sway
47	584 30 93-01	Screw LH Blade 7/16 x 1	130	596 13 32-01	Washer 13/32 x 13/16 x 12 Ga.
48	596 13 63-01	Bolt, Cup Head 3/8-16 x 2	131	532 19 42-08	Pin Cotter 5/16 Bow Tie Lock
49	532 16 55-79	Mandrel Asm, CRD, LH Threads, SVC (includes bearing, housing, shaft, felt washer, nut, bolt, and washers)	136	532 43 96-39	Washout Port Hookup
52	599 21 07-03	Bracket, 97CRD, Centr, Idler x 431	137	812 00 00-29	Ring Klip
53	595 09 81-03	Bracket, V-Idler, Bolt, Angled	138	532 44 07-43	Hose 3/8 Long 12"
55	598 96 92-01	Keeper, 97 CRD, Clutching, Arm	139	596 86 74-01	Clamp, Hose 3/8, Clear, Zinc
67	532 40 30-12	Handle Clutch Cable	140	501 57 94-01	Guard Asm. LH
68	598 90 38-02	Keeper, Belt	141	501 57 93-01	Guard Asm. RH
70	532 19 99-72	Clutch Asm Manual	152	532 44 04-88	Cable Clutch Manual w/Spring
72	581 45 41-03	Chute Upper	264	589 39 29-02	Retainer Chute Asm
75	597 02 50-01	Pulley, Idler, Flat, Clr. Zn.	--	596 55 13-01	Replacement Mower Complete
76	532 43 96-40	Washout Port			
78	532 17 39-02	Pulley Idler V-GR. Plated 4.25			
80	595 90 16-01	Bolt, Cup 5/16-18 x 3/4, Clr. Znc.			
84	589 67 61-02	Keeper Belt Mandrel			

NOTE: All component dimensions given in U.S. inches
1 inch = 25.4 mm

TRACTOR - MODEL NO. TC 238T (96051019000), PRODUCT NO. 960 51 01-90
MOWER LIFT 45

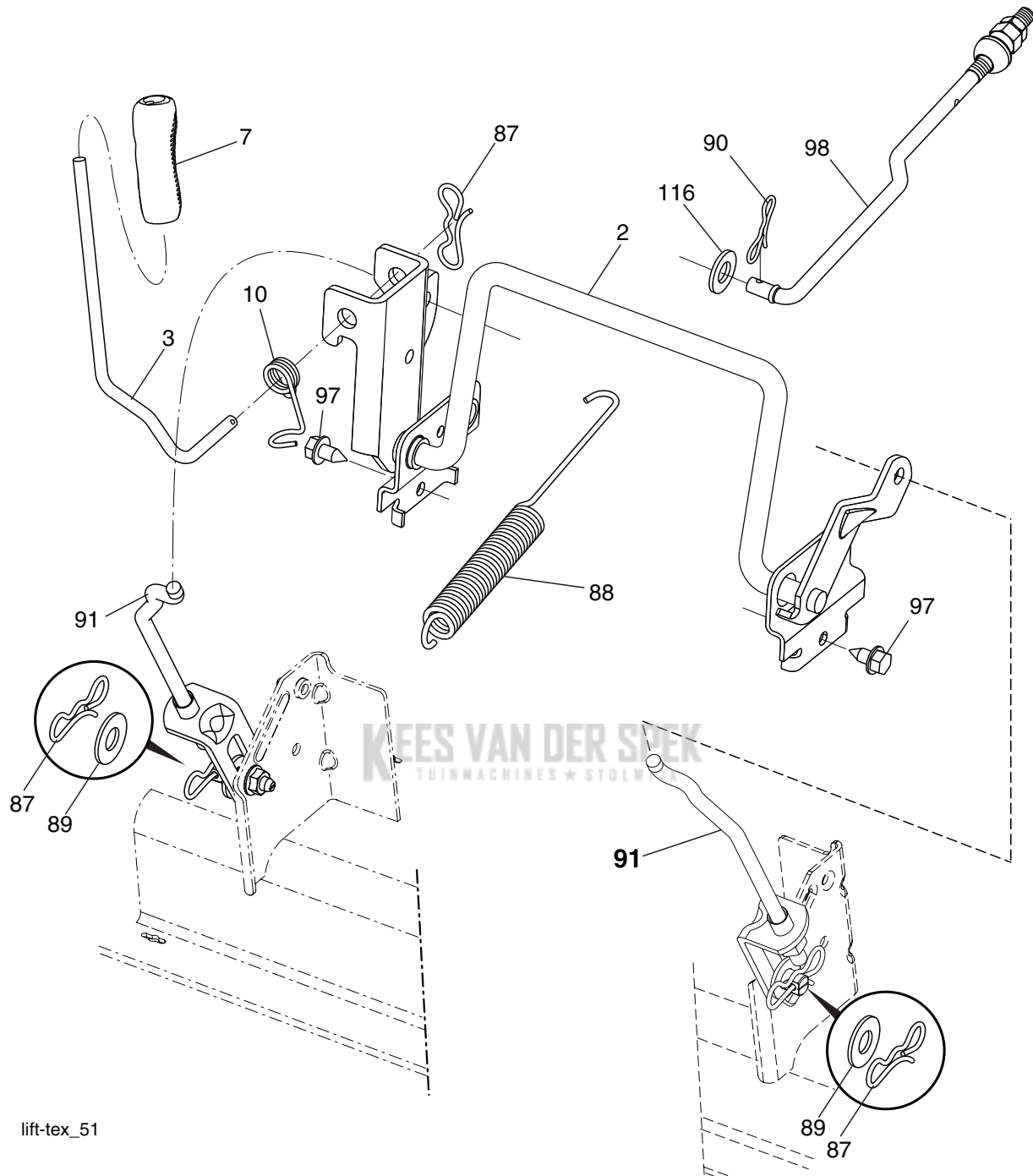

lift-tex_51

KEY NO.	PART NO.	DESCRIPTION
2	532 43 69-96	Deck Lift Weldment
3	594 01 80-01	Lever, Lift, Handle
7	580 96 23-01	Grip, Lever
10	532 19 63-14	Spring Torsion
87	532 19 42-09	Pin Cotter 7/16 Bow Tie Lock
88	532 44 54-96	Spring Lift Assist
89	819 19 19-12	Washer Clear Zinc
90	532 19 42-08	Pin Cotter 5/16 Bow Tie Lock

KEY NO.	PART NO.	DESCRIPTION
91	589 46 48-04	Link, Assy. Lift, Rear
97	596 56 40-01	Hex. Bolt w/collar 3/8-16 x 0.53
98	581 50 69-06	Link, Assy. Front, Mwr. Susp
116	594 97 65-01	Washer, Round 15/32x15/16x.065

NOTE: All component dimensions given in U.S. inches
 1 inch = 25.4 mm

TRACTOR - MODEL NO. TC 238T (96051019000), PRODUCT NO. 960 51 01-90
SEAT ASSEMBLY 42

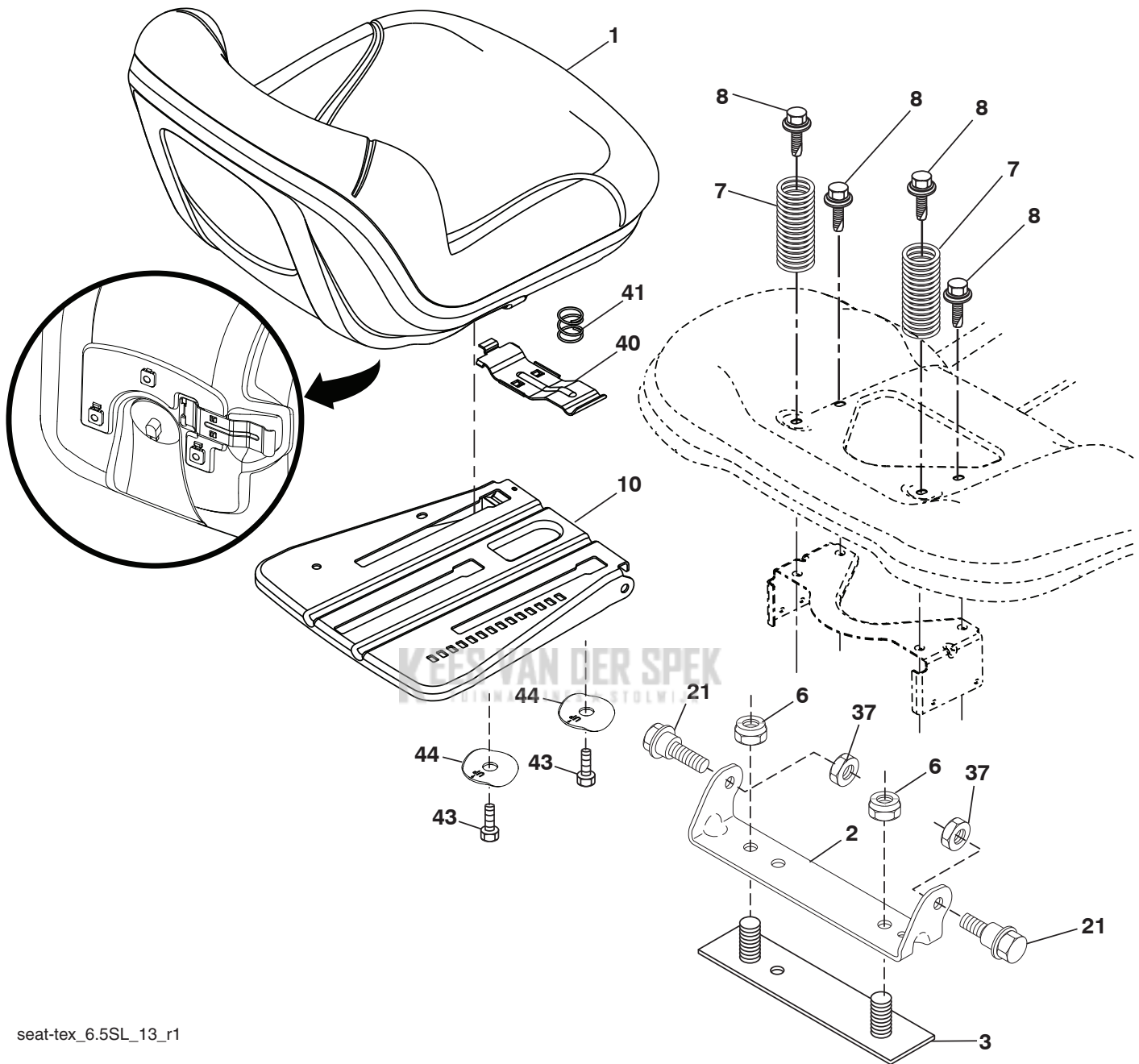

seat-tex_6.5SL_13_r1

KEY NO.	PART NO.	DESCRIPTION
1	532 43 98-22	Seat
2	532 18 01-66	Bracket Pivot Fender
3	532 14 06-75	Strap, Asm Fender
6	873 80 06-00	Nut, Lock w/Ins. 3/8-16 unc
7	589 48 35-01	Spring, Seat Cprsn
8	532 17 18-77	Bolt 5/16-18 unc x 3/4 w/Sems
10	596 65 74-02	Plate, Seat
21	587 90 78-01	Bolt, Shoulder 5/16-18 x 5/8

KEY NO.	PART NO.	DESCRIPTION
37	596 58 37-02	Nut, w/nonmetal, Ins. Blk. Zinc
40	595 08 81-02	Handle Slide Seat
41	532 19 82-00	Spring Latch Seat
43	874 76 06-12	Bolt Fin Hex 3/8-16 unc x 3/4
44	501 05 18-01	Washer Winged 3/8 ID 1.5 OD

NOTE: All component dimensions given in U.S. inches
 1 inch = 25.4 mm

TRACTOR - MODEL NO. TC 238T (96051019000), PRODUCT NO. 960 51 01-90
BAGGER **46**

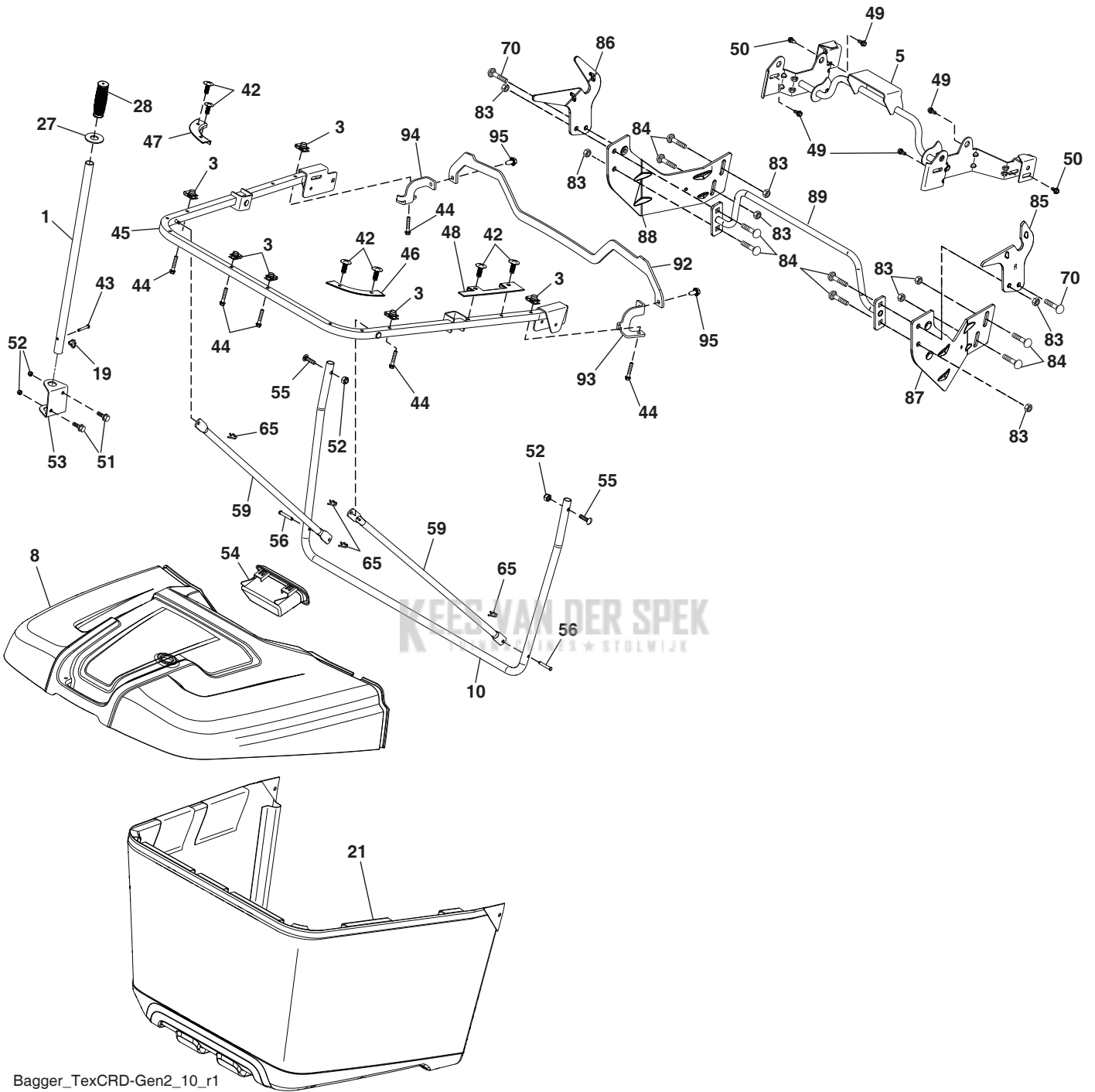

Bagger_TexCRD-Gen2_10_r1

**TRACTOR - MODEL NO. TC 238T (96051019000), PRODUCT NO. 960 51 01-90
BAGGER 46**

KEY NO.	PART NO.	DESCRIPTION
1	532 42 86-10	Tube Handle Bagger
3	532 17 48-14	Nut Push
5	532 44 37-62	Frame Asm Top Bagger
8	587 58 86-01	Cover Bagger
10	532 44 37-55	Frame Front
19	532 19 42-08	Cotter Pin 5/16 Bow Tie
21	581 33 71-03	Bag Asm
27	532 44 55-29	Grommet Rubber
28	532 16 57-87	Grip Handle Black
42	532 44 04-28	Christmas Tree Clip
43	532 12 68-75	Clevis Pin
44	532 19 96-87	Bolt 1/4-20 1.50
45	532 44 37-54	Upper U Frame Weldment
46	532 44 55-41	Bagger Corner Close-Out RH
47	532 44 40-79	Bagger Corner Close-Out LH
48	532 44 40-80	Top Bagger Side Close-Out
49	532 17 18-73	Bolt Shoulder 5/16-18 TT
50	532 17 18-77	Bolt 5/16-18 unc x 3/4 W/SEMS
51	872 11 05-06	Bolt RDHDSQNK 5/16-18 unc x 3/4
52	596 58 37-02	Nut, w/nonmetal, Ins. Blk. Zinc
53	532 44 41-95	Bracket Dump Handle
54	532 44 72-18	Bagger TOP Front Handle
55	596 03 08-01	Bolt 5/16-18 x 1/2 Gr. 5 Clr. Zn
56	532 42 03-06	Pin Clevis 1.83 OD x 1.26 long
59	532 44 47-63	Bagger Spread Tube
65	532 00 44-97	Retainer Spring 1" Zinc
70	817 00 06-12	Bolt 3/8-16 x 3/4
83	873 80 06-00	Nut Lock Hex w/Ins 3/8-16
84	596 72 82-01	Bolt, Carri. 3/8-16 x 1" Gr. 5
85	581 31 44-02	Bracket RH Pivot
86	581 31 43-02	Bracket LH Pivot
87	581 31 48-02	Bracket RH
88	581 31 47-02	Bracket LH
89	581 31 51-04	Tube Asm.
92	586 05 23-02	Bracket Top Support
93	586 05 24-02	Bracket Support RH
94	586 05 25-02	Bracket Support LH
95	817 00 05-12	Screw 5/16-18 x 3/4

NOTE: All component dimensions given in U.S. inches
1 inch = 25.4 mm

KEES VAN DER SPEK
TUINMACHINES ★ STOLWIJK