

Art.-Nr. 1278
Art.-Nr. 1251

GARDENA Bewässerungsventil 24V
Bewässerungsventil

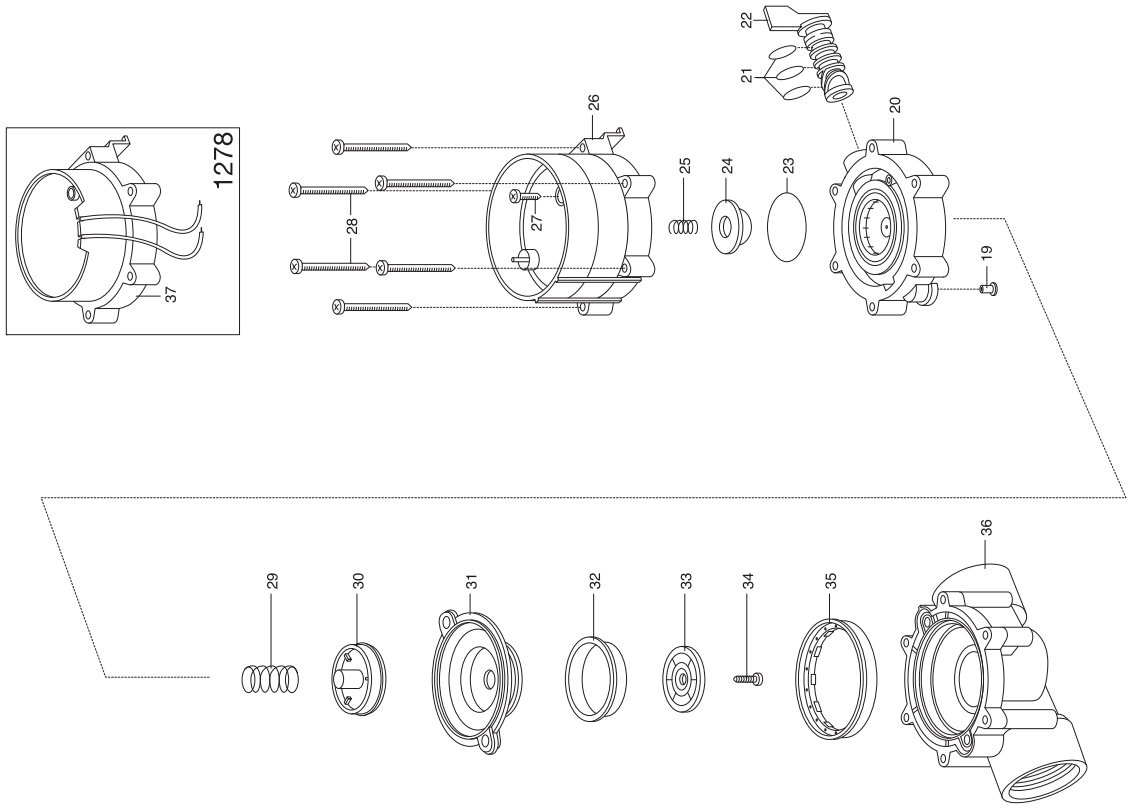

KEES VAN DER SPEK
TUINMACHINES * STOLWIJK

GARDENA

1308/1599 Magnetventildose/Bewässerungscomputer 1060 U

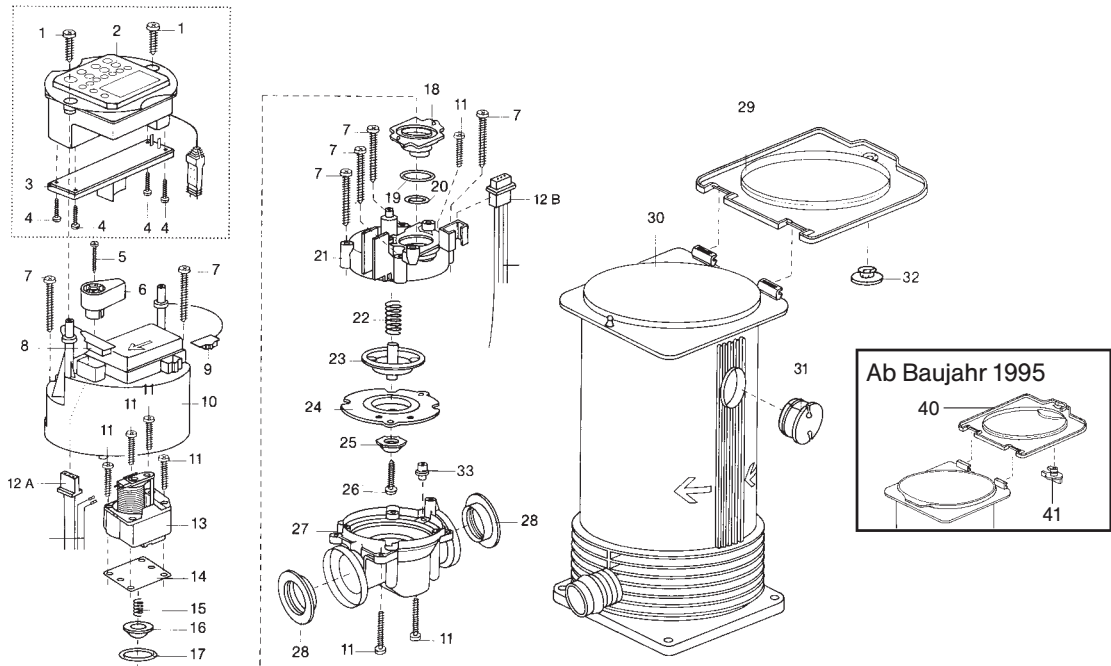

Ab Baujahr 1995

Bild Nr. Picture No.	Ersatzteil-Nr. Spare Part No.	Bezeichnung	Description	Désignation
Art. 1251 19-36 19 20 21 21,22 23 24 25 26 27 29 30-34 36	1251-00.500.00 1815-00.610.27 1251-00.660.00 913-00.680.01 1251-00.701.00 1672-00.600.11 1174-00.618.00 1174-00.610.11 1251-00.510.00 1174-00.610.07 1174-00.610.08 1251-00.550.00 1251-00.500.31 1251-00.540.00 1815-00.610.38	Bewässerungsventil 9 V - 1" 1" Bew. Ventil 9 V (Art. 1251-20) Steuerdüse rot Ventildeckel O-Ring 7,5x2 Küken, vollst. O-Ring 24x2 Magnetplatte, vollst. Druckfeder, klein Elektromagnet, vollst. Blechschaube 3,5x25-F-H Druckfeder, groß Membrane, vollst. Ventilkörper Feinfilter Mylar-Folie rund, 4 Typ A, 50µm	Watering Valve 9 V - 1" Watering valve 1" 9 V (=Art. 1251) Control nozzle rot Valve cover O-ring 7,5x2 Turning knob, cpl. O-ring 24x2 Magnetic plate, cpl. Pressure spring, small Electromagnet, cpl. Sheet metal screw 3,5x25-F-H Pressure spring, large Diaphragm, cpl. Valve body Fine filter Mylar foil round, typ A, 50µm	Electrovanne 9 V - 1" Electrovanne 9 V 1" (Réf. 1251-20) Buse de commande rouge Couvercle de soupape Joint torique 7,5x2 Bouton rotatif, cpl. O-ring 24x2 Clapet magnétique, cpl. Ressort de pression, petit Électro-aimant, cpl. Vis à tôle 3,5x25-F-H Ressort de pression, grand Diaphragme, cpl. Corps de soupape Filtre fin Feuille mylar rond, 4 typ A, 50µm
Art. 1278 37	1278-00.610.00 1278-00.600.02	Bewässerungsventil 24 V - 1" Elektromagnet, vollst. Mylarfolie 4 Typ A, 190 µm Alle anderen Ersatzteile wie bei Art. 1251	Watering Valve 24 V - 1" Electromagnet, cpl. Mylar foil typ A, 190 µm All other spare parts see Art. 1251	Electrovanne 24V - 1" Électro-aimant, cpl. Feuille mylar typ A, 190 µm Pour toutes les autres pièces, voir réf. 1251
Art. 1275 Art. 1276	1275-00.900.01	Bewässerungssteuerung 6040 bis Baujahr 2004 Bewässerungssteuerung 4040 modular Netzteil 24 V	Watering Controls 6040 until 2004 Watering Control System 4040 modular Power unit 24 V	Programmateur mural 6040 jusqu'à 2004 Programmateur 4040 modulable Transformateur 24 V
Art. 1277	1277-00.901.00	Erweiterungsmodul 2040 Polybeutel, kpl.	Extension Module Accessory bag, cpl.	Module d'extension 2040 Sachet d'accessoires, cpl.
Art. 1283 Art. 1284	1283-00.900.01 1283-00.900.02	Classic Bewässerungssteuer. 4030 Classic Bewässerungssteuer. 6030 Netzteil 24 V Sensoradapter	Classic Irrig. Control System 4030 Classic Irrig. Control System 6030 Power unit 24 V Sensor adapter	Programmateur 4030 Classic Programmateur 6030 Classic Transformateur 24 V Adaptateur du sonde
Art. 1303	1308-00.900.01	Bewässerungssteuerung 6030 bis Baujahr 1997 Adapterkabel vollst. 1303-1240	Six Channel Water Controller until 1997 Adapter cpl. for 1303-1240	Programmateur mural 6030 jusqu'à 1997 Câble d'adaptation cpl. p. 1303-1240
Art. 1599 1 2-4	853-00.002.16 1599-00.690.00	Bewässerungscomputer 1060 U bis Baujahr 1997 Blechschaube 4,2x22-C-H Steuerteil 24 h, vollst. Alle anderen Teile wie bei Art. 1308	Water Computer 1060 U until 1997 Sheet metal screw 4,2x22-C-H Control component 24 h, cpl. All other spare parts see Art. 1308	Programmateur d'arrosage 1060 U jusqu'à 1997 Vis à tôle 4,2x22-C-H Boite de commande 24 H, cpl. Pour toutes les autres pièces, voir réf. 1308
Art. 1308 5 6 7 11 14 15 16 17 18 19 20 22 23 24 25 26 28 29 30 31 32 33 40 41	1599-00.600.17 1599-00.600.12 1182-00.600.02 1174-00.610.07 1174-00.610.04 1174-00.610.11 1174-00.618.00 1672-00.600.11 1174-00.610.03 1174-00.610.05 900-00.101.06 1174-00.610.08 1174-00.612.02 1174-00.662.01 1174-00.612.03 882-00.007.11 1599-00.600.01 1594-00.600.07 1533-00.600.11 1255-00.600.40 1594-00.600.11 1815-00.610.27 1594-00.600.47 1594-00.600.51 1319-20.000.00 1308-00.708.00	Magnetventildose bis Baujahr 1997 Blechschaube 2,2x9,5-C-H Hebel Blechschaube 4,2x38-C-H Blechschaube 3,5x25-F-H Abdeckfolie Druckfeder, klein Magnetplatte, vollst. O-Ring 24x2 Ventilplatte O-Ring 18,72x2,62 O-Ring 10,5x2,7 Druckfeder, groß Membranflansch, rot Membrane Stützkegel, rot Blechschaube 3,5x13-F-H Dichtung Deckel, grau Ventildose Kabelklemme Knopf, rot Steuerdüse rot Deckel, grau Drehknopf Verlängerungskabel 20 m Reparatur-Set für Art. 1308	Solenoid Valve Box until 1997 Sheet metal screw 2,2x9,5-C-H Lever Sheet metal screw 4,2x38-C-H Sheet metal screw 3,5x25-F-H Cover foil Pressure spring, small Magnetic plate, cpl. O-ring 24x2 Valve plate O-ring 18,72x2,62 O-ring 10,5x2,7 Pressure spring, large Diaphragm flange, red Diaphragm Support cone, red Sheet metal screw 3,5x13-F-H Washer Cover, grey Valve box Cable clip Button, red Control nozzle rot Cover, grey Turning knob Extension cable 20 m Repair set for Art. 1308	Electrovanne jusqu'à 1997 Vis à tôle 2,2x9,5-C-H Lever Vis à tôle 4,2x38-C-H Vis à tôle 3,5x25-F-H Protège-contact Ressort de pression, petit Clapet magnétique, cpl. Joint torique 24x2 Support de clapet Joint torique 18,72x2,62 Joint torique 10,5x2,7 Ressort de pression, grand Flanc de diaphragme, rouge Diaphragme Cone de support, rouge Vis à tôle 3,5x13-F-H Joint Couvercle, gris Boite à soupape Bouchon passe-fils Bouton, rouge Buse de commande rouge Couvercle, gris Bouton rotatif Cable-rallonge, 20 m Kit de réparation pour réf. 1308
Art. 1519-29	245-00.106.00 954-00.102.17 1519-00.600.01	Gewindeadapter für Art. 1308 bis Baujahr 2006 O-Ring 18,3x3,6 Überwurfmutter, schwarz Gewindeadapter Nur die aufgeführten Teile sind lieferbar!	Threaded adapter for Art. 1308 until 2006 O-ring 18,3x3,6 Union nut, black Threaded adapter Only the mentioned spare parts are available!	Adaptateur fileté pour réf. 1308 jusqu'à 2006 Joint torique 18,3x3,6 Écrou-raccord, noir Adaptateur fileté Seules les pièces indiquées sont disponibles!